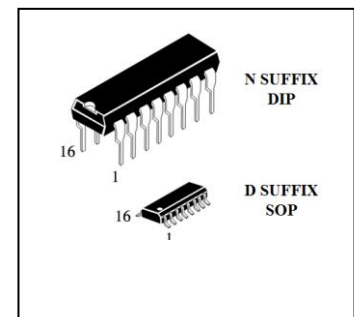


# PWM Control Circuit

**IL494**

The IL494 incorporates on a single monolithic chip all the functions required in the construction of a pulse-width-modulation control circuit. Designed primarily for power supply control, the IL494 contains an on-chip 5-volt regulator, two error amplifiers, adjustable oscillator, dead-time control comparator, pulse-steering flip-flop, and output-control circuitry. The uncommitted output transistors provide either common-emitter or emitter-follower output capability. Push-pull or single-ended output operation may be selected through the output-control function. The architecture of the IL494 prohibits the possibility of either output being pulsed twice during push-pull operation.



## FEATURE

- Complete PWM Power Control Circuitry
- Uncommitted Outputs for 200 mA Sink or Source
- Output Control Selects Single-Ended or Push-Pull Operation
- Internal Circuitry Prohibits Double Pulse at Either Output
- Internal Regulator Provides a Stable 5 V Reference Supply
- Variable Dead-Time Provides Control Over Total Range

## PIN ASSIGNMENT

NONINV. INPUT	1 ●	16	NONINV. INPUT
INV. INPUT	2	15	INV. INPUT
FEEDBACK	3	14	REF OUT
DEAD TIME CONTROL	4	13	OUTPUT CONTROL
C <sub>T</sub>	5	12	V <sub>CC</sub>
R <sub>T</sub>	6	11	C2
GND	7	10	E2
C1	8	9	E1

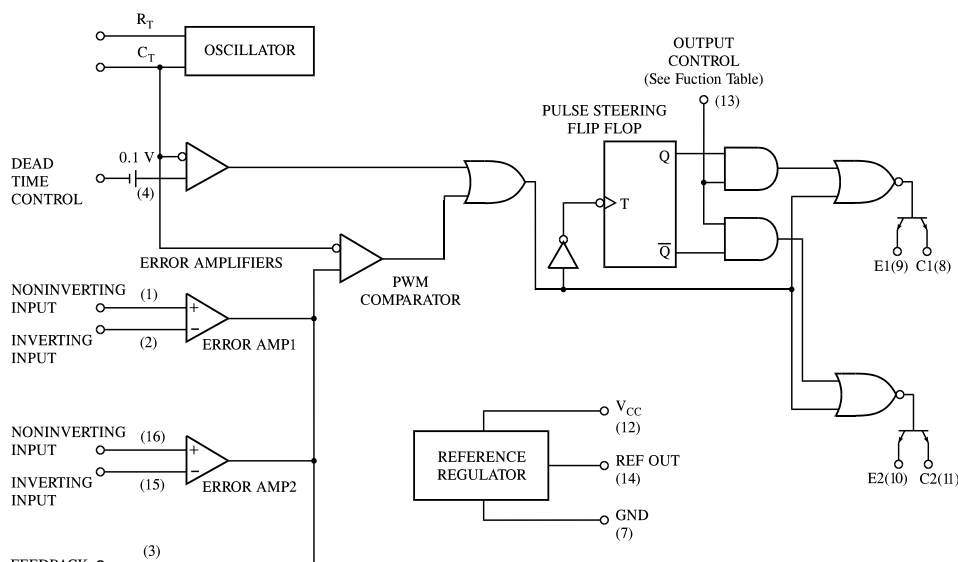
## ORDERING INFORMATION

Device	Operating Temperature Range	Package	Shipping
IL494N	T <sub>A</sub> = -20° to 85° C for all packages	Plastic DIP-16	Tube
IL494D		SOP-16	Tube
IL494DT		SOP-16	Tape& Reel

## FUNCTION TABLE

Output Control	Output Function
Grounded	Single-ended or Parallel Output
At V <sub>ref</sub>	Normal Push-Pull Operation

## LOGIC DIAGRAM



**MAXIMUM RATINGS**

Symbol	Parameter	Value	Unit
V <sub>CC</sub>	Supply Voltage	41	V
V <sub>I</sub>	Amplifier Input Voltage	V <sub>CC</sub> +0.3	V
V <sub>O</sub>	Collector Output Voltage	41	V
	Collector Output Current	250	mA
T <sub>stg</sub>	Storage Temperature	-65 to +150	°C

\* Stresses beyond those listed under “absolute maximum ratings” may cause permanent damage to the device. These are stress ratings only and functional operation of the device at these or any other conditions beyond those indicated under “recommended operating conditions” is not implied. Exposure to absolute-maximum-rated conditions for extended periods may affect device reliability.

**RECOMMENDED OPERATING CONDITIONS**

Symbol	Parameter	Min	Max	Unit
V <sub>CC</sub>	Supply Voltage	7	40	V
V <sub>I</sub>	Amplifier Input Voltage	-0.3	V <sub>CC</sub> - 2	V
V <sub>O</sub>	Collector Output Voltage		40	V
	Collector Output Current (Each Transistor)		200	mA
	Current Into Feed back Terminal		0.3	mA
C <sub>T</sub>	Timing Capacitor	0.47	10.000	nF
R <sub>T</sub>	Timing Resistor	1.8	500	KΩ
	Oscillator Frequency	1	300	KHz
T <sub>A</sub>	Operating Free-Air Temperature	-20	+85	°C

**ELECTRICAL CHARACTERISTICS** (Temperature  $-20 \sim 85^{\circ}\text{C}$ ,  $V_{\text{CC}} = 15 \text{ V}$ ,  $f = 10 \text{ kHz}$ )

Symbol	Parameter	Test Conditions	Min	Max	Unit
<b>Reference Section</b>					
$V_{\text{ref}}$	Output Voltage	$I_{\text{O}}=1 \text{ mA}$	4.90	5.10	V
$V_{\text{regin}}$	Output regulation	$V_{\text{CC}}=7 \text{ V to } 40 \text{ V}$ , $T_{\text{A}}=25^{\circ}\text{C}$		25	mV
$V_{\text{regout}}$	Input regulation	$I_{\text{O}}=1 \text{ to } 10 \text{ mA}$ , $T_{\text{A}}=25^{\circ}\text{C}$		15	mV
$\Delta V_{\text{ref}}$	Output Voltage change with temperature	$T_{\text{A}}= -20^{\circ}\text{C to } 85^{\circ}\text{C}$		1	%
$I_{\text{SC}}$	Short-circuit output current (Note 1)	$V_{\text{ref}}=0$		50	mA
<b>Oscillator Section</b>					
$f_{\text{OSC}}$	Frequency	$C_{\text{T}}=0.01 \mu\text{F}$ , $R_{\text{T}}=12 \text{ k}\Omega$	6	14	KHz
$\delta f_{\text{OSC}}$	Standard deviation of frequency (Note 2)	All values of $V_{\text{CC}}$ , $C_{\text{T}}$ , $R_{\text{T}}$ , $T_{\text{A}}$ Constant		15	%
$\delta f_{\text{OSC}(\Delta V)}$	Frequency change with voltage	$V_{\text{CC}}= 7 \text{ V to } 40 \text{ V}$ , $T_{\text{A}}=25^{\circ}\text{C}$		10	%
$\delta f_{\text{OSC}(\Delta T)}$	Frequency change with temperature	$C_{\text{T}}=0.01 \mu\text{F}$ , $R_{\text{T}}=12 \text{ k}\Omega$ $T_{\text{A}}= -20^{\circ}\text{C to } 85^{\circ}\text{C}$		2	%
<b>Dead Time Control Section</b>					
$I_{\text{IB}(2\text{T})}$	Input bias current (pin 4)	$V_{\text{I}}= 0 \text{ to } 5.25 \text{ V}$		-10	$\mu\text{A}$
$\text{DC}_{\text{max}}$	Maximum duty cycle, each output	$V_{\text{I}(\text{pin } 4)}=0 \text{ V}$	45		%
$V_{\text{THD}}$	Input threshold voltage (pin 4)	Zero duty cycle		3.3	V
		Maximum duty cycle	0		
<b>Error Amp Section</b>					
$V_{\text{IO}}$	Input offset voltage	$V_{\text{O}(\text{pin } 3)}=2.5 \text{ V}$		10	mV
$I_{\text{IO}}$	Input offset current	$V_{\text{O}(\text{pin } 3)}=2.5 \text{ V}$		250	nA
$I_{\text{IB}}$	Input bias current	$V_{\text{O}(\text{pin } 3)}=2.5 \text{ V}$		1	$\mu\text{A}$
	Common-mode input voltage range	$V_{\text{CC}}= 7 \text{ V to } 40 \text{ V}$	LOW	-0.3	V
			HIGH	$V_{\text{CC}} - 2$	
$A_{\text{vol}}$	Open-loop voltage amplification	$\Delta V_{\text{O}}=3 \text{ V}$ , $V_{\text{O}}=0.5 \text{ to } 3.5 \text{ V}$	70		dB
$f_{\text{b}}$	Unity-gain bandwidth		100		kHz
CMRR	Common-mode rejection ratio	$V_{\text{CC}}=40 \text{ V}$ , $T_{\text{A}}=25^{\circ}\text{C}$	65		dB
$I_{\text{O}}$	Output sink current (pin 3)	$V_{\text{ID}}=-15 \text{ mV to } -5 \text{ V}$ , $V_{\text{O}(\text{pin } 3)}=0.7 \text{ V}$	0.3		mA
$I_{\text{O}+}$	Output source current (pin 3)	$V_{\text{ID}}=15 \text{ mV to } 5 \text{ V}$ , $V_{\text{O}(\text{pin } 3)}=3.5 \text{ V}$	-2		mA

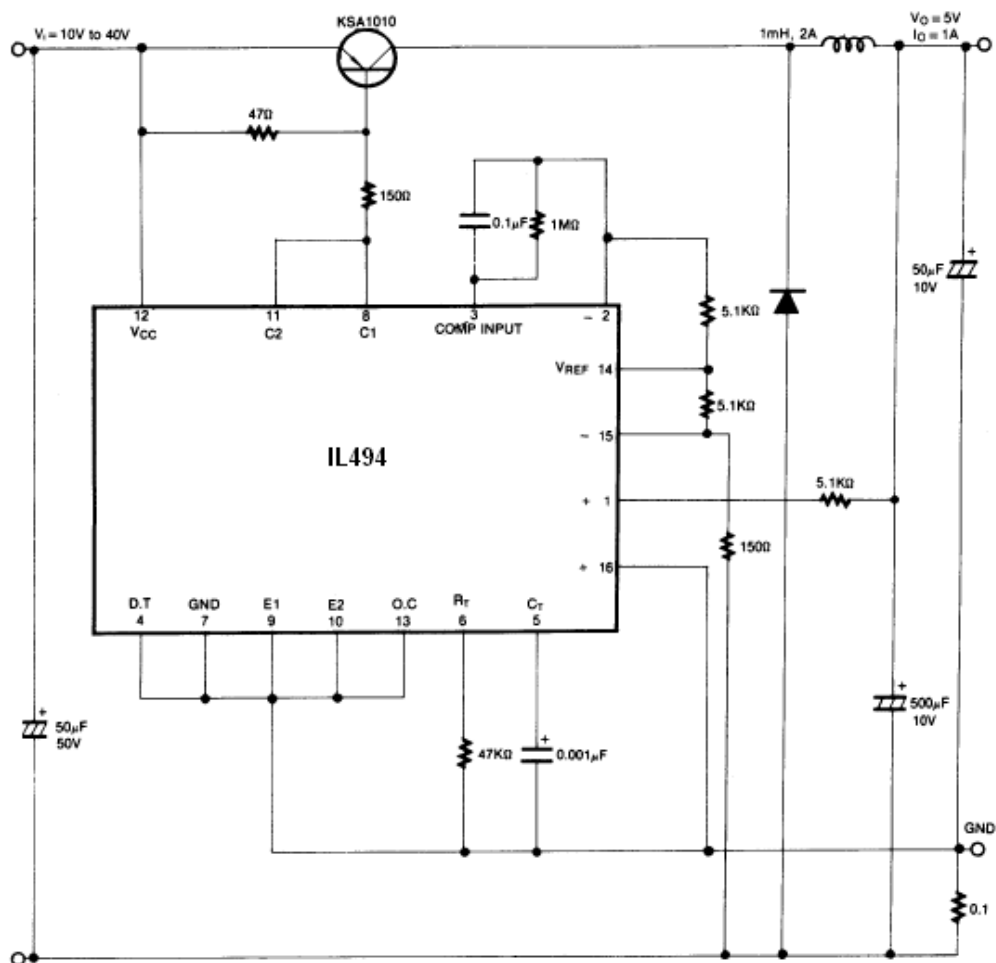
**ELECTRICAL CHARACTERISTICS** (Temperature -20 ~ 85°C, V<sub>CC</sub> = 15 V, f=10 kHz)

Symbol	Parameter	Test Conditions	Min	Max	Unit
<b>PWM Comparator Section</b>					
V <sub>THP</sub>	Input threshold voltage (pin 3)	Zero duty cycle		4.5	V
I <sub>I</sub>	Input sink current (pin 3)	V <sub>O(pin 3)</sub> =0.7 V	0.3		mA
<b>Switching Characteristics</b>					
t <sub>rc</sub>	Output voltage rise time	Common-emitter configuration		200	ns
t <sub>fc</sub>	Output voltage fall time	Common-emitter configuration		100	ns
t <sub>rf</sub>	Output voltage rise time	Emitter-follower configuration		200	ns
t <sub>ff</sub>	Output voltage fall time	Emitter-follower configuration		100	ns
<b>Output Section</b>					
I <sub>C(off)</sub>	Collector off-state current	V <sub>CE</sub> =40 V, V <sub>CC</sub> =40 V		100	μA
I <sub>E(off)</sub>	Emitter off-state current	V <sub>CC</sub> =V <sub>C</sub> =40 V, V <sub>E</sub> =0		-100	μA
V <sub>SAT</sub>	Collector-emitter saturation voltage	Common-emitter V <sub>E</sub> =0, I <sub>C</sub> =200 mA		1.3	V
		Emitter-follower V <sub>C</sub> =15 V, I <sub>E</sub> =-200 mA		2.5	
I <sub>OCH</sub>	Output control input current	V <sub>I</sub> =V <sub>ref</sub>		3.5	mA
<b>Total Device</b>					
I <sub>CC</sub>	Standby supply current	All other inputs & outputs open	V <sub>CC</sub> =15 V	10	mA
			V <sub>CC</sub> =40 V	15	
I <sub>CCA</sub>	Average supply current	V <sub>(pin 4)</sub> =2 V		17	mA

- Notes:** 1. Duration of the short circuit should not exceed one second.  
 2. Standard deviation is a measure of the statistical distribution about the mean as derived from the formula

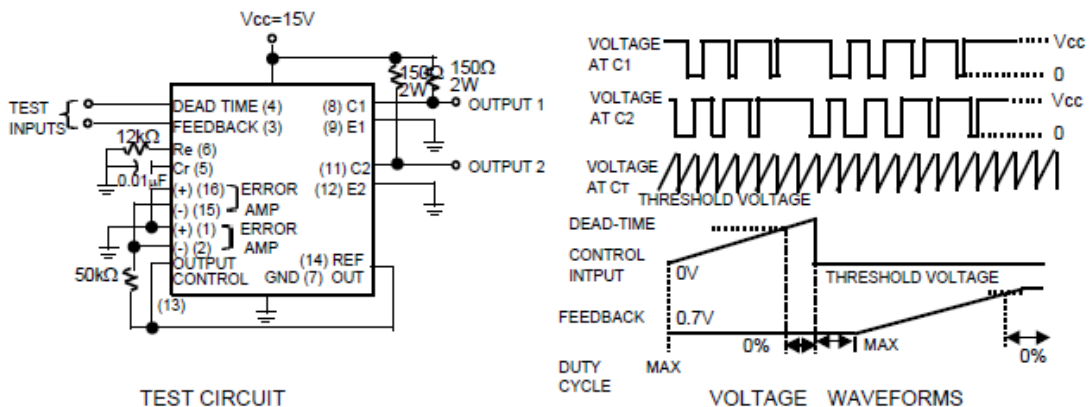
$$\sigma = \sqrt{\frac{\sum_{n=1}^N (x_n - \bar{x})^2}{N - 1}}$$

### Typical Application Pulse Width Modulated Step-down Converter

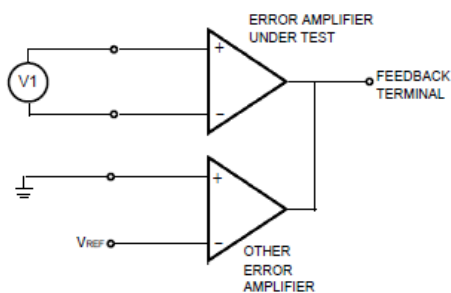


## Parameter Measurement Information

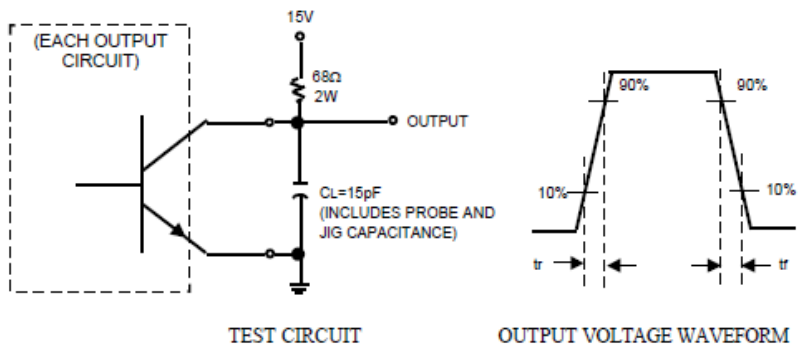
### 1. Dead time and Feedback Control



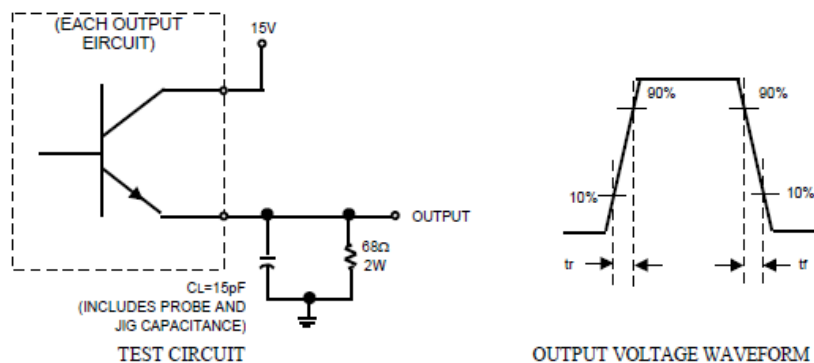
### 2. Error Amplifier Characteristics



### 3. Common-Emitter Configuration



### 4. Emitter-Follower Configuration



Typical Performance Curves

FIGURE 1 – OSCILLATOR FREQUENCY vs. TIMING RESISTANCE

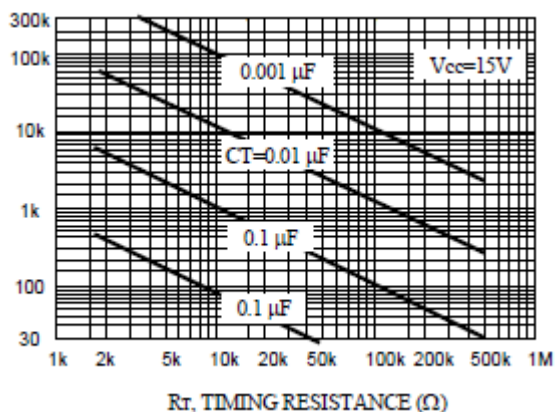


FIGURE 2 – OPEN LOOP VOLTAGE GAIN AND PHASE vs. FREQUENCY

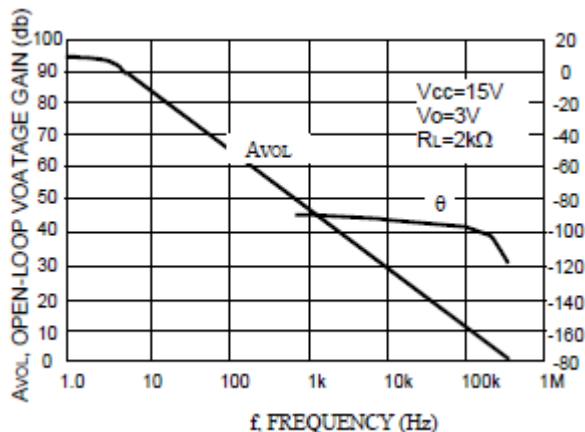


FIGURE 3 – PERCENT DEAD TIME vs. OSCILLATOR FREQUENCY

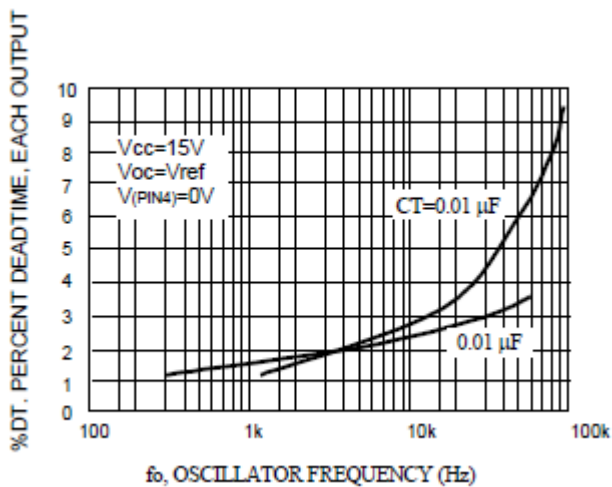
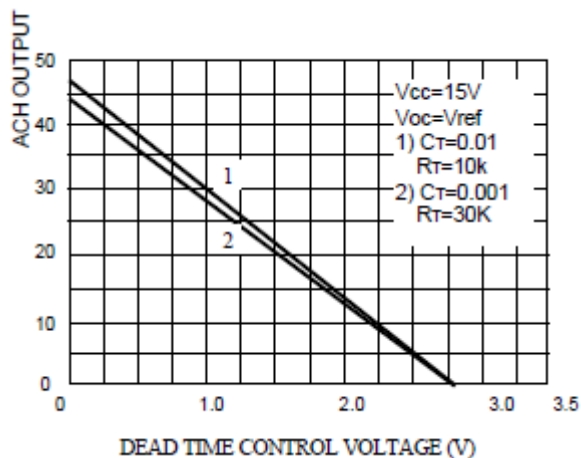
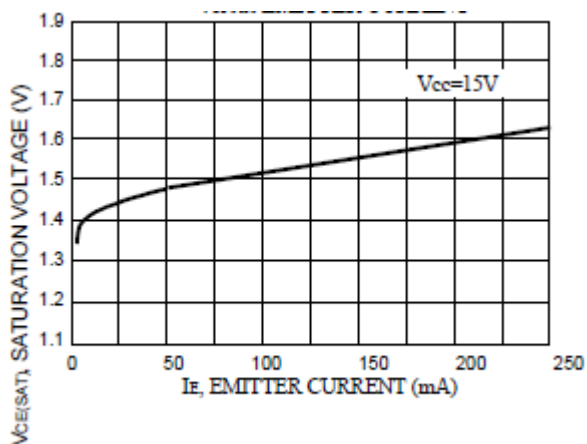


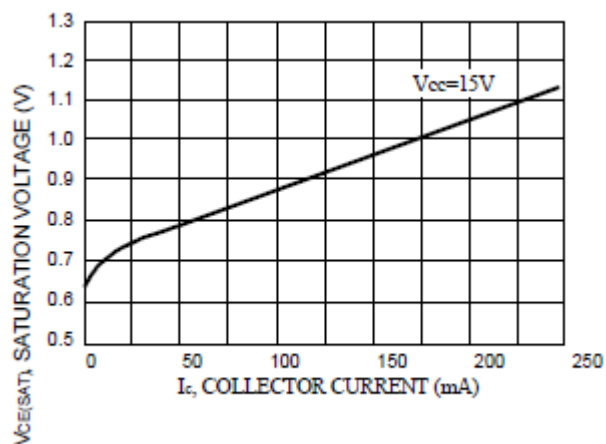
FIGURE 4 – PERCENT DUTY CYCLE vs. DEAD-TIME CONTROL VOLTAGE



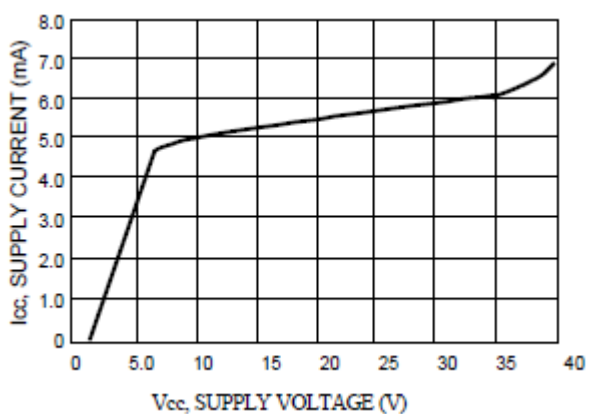
**FIGURE 5 – EMITTER-FOLLOWER CONFIGURATION OUTPUT-SATURATION VOLTAGE vs. EMITTER CURRENT**



**FIGURE 6 – COMMON-EMITTER CONFIGURATION OUTPUT-SATURATION VOLTAGE vs. COLLECTOR CURRENT**

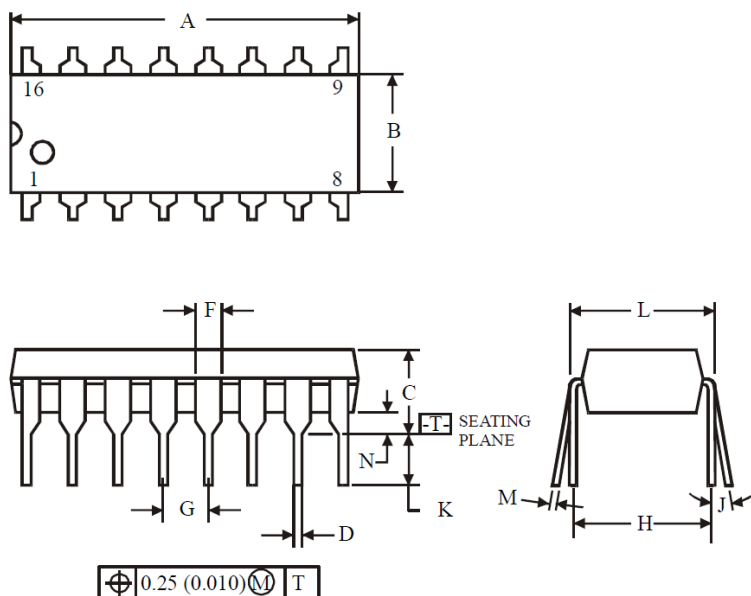
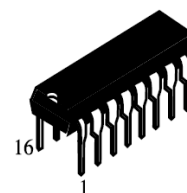


**FIGURE 7 – STANDBY-SUPPLY CURRENT vs. SUPPLY VOLTAGE**





**N SUFFIX DIP**  
**(MS - 001BB)**

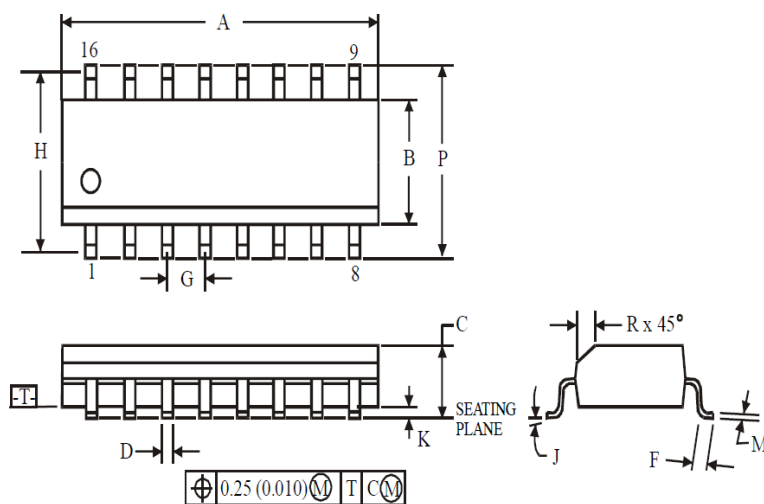


	Dimension, mm	
Symbol	MIN	MAX
A	18.67	19.69
B	6.10	7.11
C		5.33
D	0.36	0.56
F	1.14	1.78
G	2.54	
H	7.62	
J	0°	10°
K	2.92	3.81
L	7.62	8.26
M	0.20	0.36
N	0.38	

**NOTES:**

- Dimensions "A", "B" do not include mold flash or protrusions.  
Maximum mold flash or protrusions 0.25 mm (0.010) per side.

**D SUFFIX SOP**  
**(MS - 012AC)**



	Dimension, mm	
Symbol	MIN	MAX
A	9.80	10.00
B	3.80	4.00
C	1.35	1.75
D	0.33	0.51
F	0.40	1.27
G	1.27	
H	5.72	
J	0°	8°
K	0.10	0.25
M	0.19	0.25
P	5.80	6.20
R	0.25	0.50

**NOTES:**

- Dimensions A and B do not include mold flash or protrusion.
- Maximum mold flash or protrusion 0.15 mm (0.006) per side for A; for B - 0.25 mm (0.010) per side.