

Programmable Precision Reference

TL431Z

Description

The TL431Z is a three-terminal adjustable regulator series with a guaranteed thermal stability over applicable temperature ranges. The output voltage may be set to any value between V_{ref} (approximately 2.5 volts) and 40 volts with two external resistors. These devices have a typical dynamic output impedance of 0.2Ω . Active output circuitry provides a very sharp turn-on characteristic, making these devices excellent replacement for zener diodes in many applications. The TL431Z is characterized for operation from -40°C to $+125^{\circ}\text{C}$.

Pin Connections

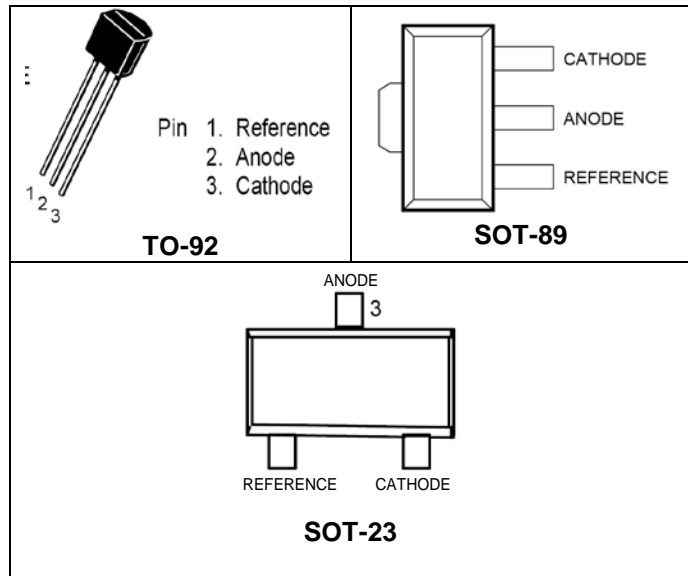

Features

- Programmable Output Voltage to 40V
- Low Dynamic Output Impedance 0.2Ω
- Sink Current Capability of 0.1 mA to 100 mA
- Equivalent Full-Range Temperature Coefficient of $50\text{ ppm}/^{\circ}\text{C}$
- Temperature Compensated for Operation over Full Rated Operating Temperature Range
- Low Output Noise Voltage
- Fast Turn on Response
- TO-92, SOT-89, SOT-23 packages

Ordering Information

Product Number	Reference Input Voltage	Package
TL431ZCLF TL431ZCLS	0.5%	TO-92
TL431ZCS		SOT-23
TL431ZCP		SOT-89
TL431ZALF TL431ZALS	1%	TO-92
TL431ZAS		SOT-23
TL431ZAP		SOT-89
TL431ZLF TL431ZLS	2%	TO-92
TL431ZS		SOT-23
TL431ZP		SOT-89

Symbol

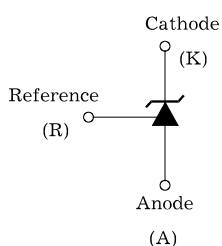

Functional Block Diagram

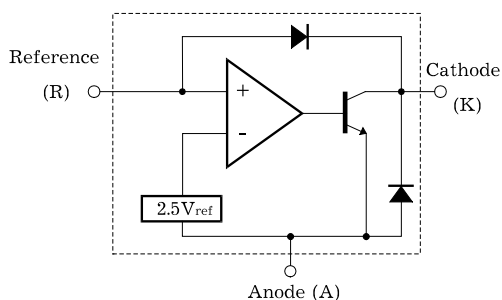

Equivalent Schematic

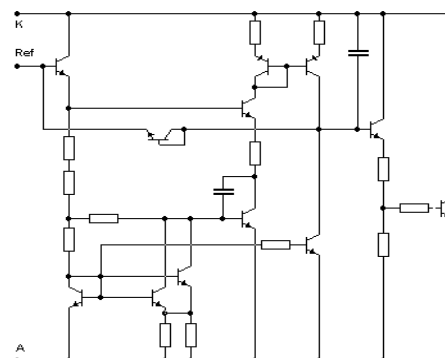

ABSOLUTE MAXIMUM RATINGS

(Operating temperature range applies unless otherwise specified)

Characteristic	Symbol	Value	Unit
Cathode Voltage	V_{KA}	44	V
Cathode Current Range (Continuous)	I_K	-100 ~ 150	mA
Reference Input Current Range	I_{REF}	0.05 ~ 10	mA
Power Dissipation at 25°C: TO – 92 Package ($R_{\theta JA} = 178^{\circ}C/W$)	P_D	0.7	W
SOT Package ($R_{\theta JA} = 625^{\circ}C/W$)		0.2	W
Junction Temperature Range	T_J	0 ~ 150	°C
Operating Temperature Range	T_g	-40 ~ 125	°C
Storage Temperature Range	T_{stg}	-65 ~ 150	°C

* Stresses beyond those listed under “absolute maximum ratings” may cause permanent damage to the device. These are stress ratings only, and functional operation of the device at these or any other conditions beyond those indicated under “recommended operating conditions” is not implied. Exposure to absolute-maximum-rated conditions for extended periods may affect device reliability.

RECOMMENDED OPERATING CONDITIONS

Characteristic	Symbol	Min	Typ	Max	Unit
Cathode to Anode Voltage	V_{KA}	V_{REF}		40	V
Cathode Current	I_K	0.5		100	mA

ELECTRICAL CHARACTERISTICS

($T_a = 25^{\circ}\text{C}$, $V_{KA} = V_{REF}$, $I_K = 10\text{mA}$ unless otherwise specified)

Characteristic	Symbol	Test Condition	Min	Typ	Max	Unit
Reference Input Voltage	V_{REF}	$V_{KA} = V_{REF}$, $I_K = 10\text{mA}$ TL431Z (2%) TL431Z-A (1%) TL431Z-C (0.5%)	2.440 2.470 2.482	2.495	2.550 2.520 2.508	V
Deviation of Reference Input Voltage Over Full Temperature Range	$V_{REF(dev)}$	$T_{min} \leq T_a \leq T_{max}$		3	17	MV
Ratio of Change in Reference Input Voltage to the Change in Cathode Voltage	$\frac{\Delta V_{REF}}{\Delta V_{KA}}$	$\Delta V_{KA} = 10\text{V} - V_{REF}$ $\Delta V_{KA} = 36\text{V} - 10\text{V}$		-1.4 -1.0	-2.7 -2.0	mV/V
Reference Input Current	I_{REF}	$R_1 = 10\text{K}\Omega$, $R_2 = \infty$		1.8	4	μA
Deviation of Reference Input Current Over Full Temperature Range	$I_{REF(dev)}$	$R_1 = 10\text{K}\Omega$, $R_2 = \infty$		0.4	1.2	μA
Minimum Cathode Current for Regulation	$I_{K(min)}$			0.25	0.5	mA
Off-State Cathode Current	$I_{K(off)}$	$V_{KA} = 40\text{V}$, $V_{REF} = 0$		0.17	0.9	μA
Dynamic Impedance	Z_{KA}	$I_K = 10\text{mA}$ to 100mA , $f \leq 1.0\text{KHz}$		0.27	0.5	Ω

Note :

1. The deviation parameter ΔV_{ref} is defined as the difference between the maximum and minimum values obtained over the full operating ambient temperature range that applies

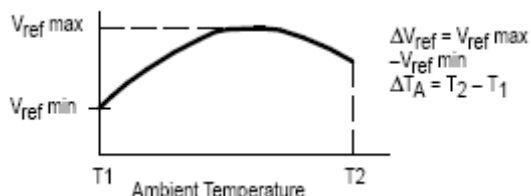

The average temperature coefficient of the reference input voltage, αV_{ref} is defined as:

$$V_{ref\ \frac{ppm}{^{\circ}\text{C}}} = \frac{\left(\frac{\Delta V_{ref}}{V_{ref\ @\ 25^{\circ}\text{C}}} \right) \times 10^6}{\Delta T_A} = \frac{\Delta V_{ref} \times 10^6}{\Delta T_A (V_{ref\ @\ 25^{\circ}\text{C}})}$$

αV_{ref} can be positive or negative depending on whether $V_{ref\ Min}$ or $V_{ref\ Max}$ occurs at the lower ambient temperature. (Refer to Figure 6.)

Example : $\Delta V_{ref} = 8.0\text{ mV}$ and slope is positive,

$$V_{ref\ @\ 25^{\circ}\text{C}} = 2.495\text{ V}, \Delta T_A = 70^{\circ}\text{C}$$

$$\alpha V_{ref} = \frac{0.008 \times 10^6}{70 (2.495)} = 45.8\text{ ppm}/^{\circ}\text{C}$$

2. The dynamic impedance Z_{KA} is defined as

$$|Z_{KA}| = \frac{\Delta V_{KA}}{\Delta I_K}$$

When the device is programmed with two external resistors, R_1 and R_2 , (refer to Figure 2) the total dynamic impedance of the circuit is defined as:

$$|Z_{KA}'| = |Z_{KA}| \left(1 + \frac{R_1}{R_2} \right)$$

TEST CIRCUITS

Fig.1. Test Circuit for $V_{KA} = V_{REF}$

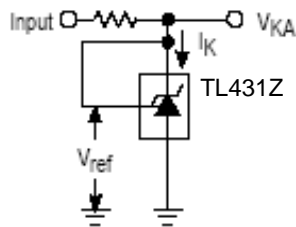

Fig.2. Test Circuit for $V_{KA} \geq V_{REF}$

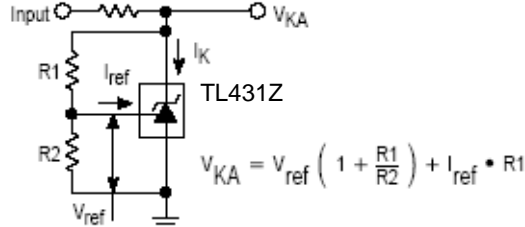

Fig.3. Test Circuit for I_{off}

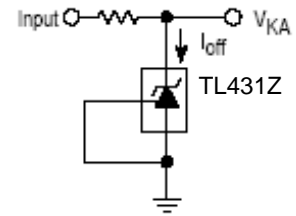

Figure 4. Cathode Current versus Cathode Voltage

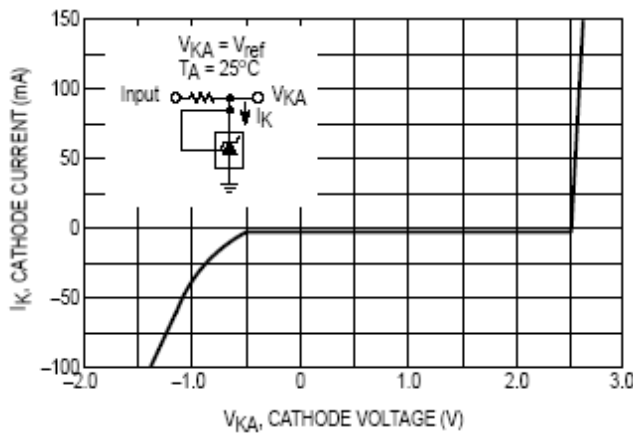

Figure 5. Cathode Current versus Cathode Voltage

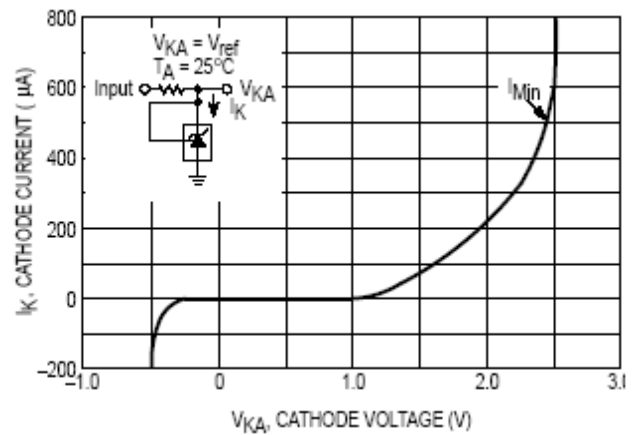

Figure 6. Reference Input Voltage versus Ambient Temperature

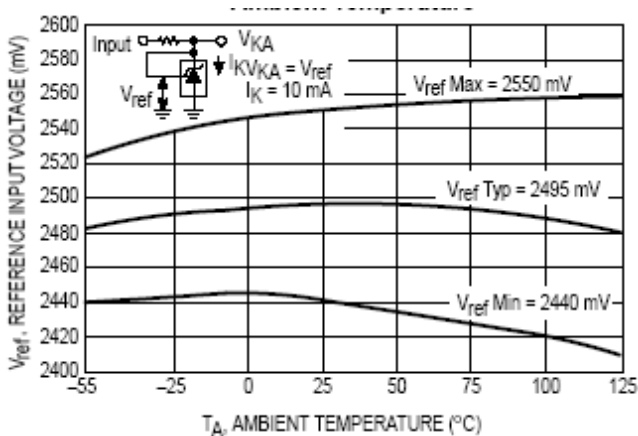

Figure 7. Reference Input Current versus Ambient Temperature

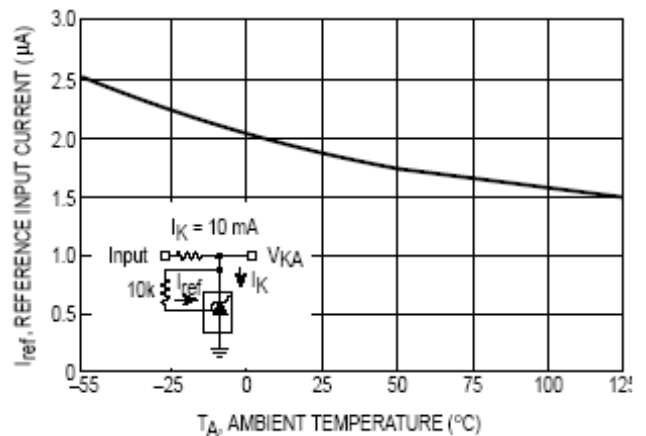

Figure 8. Change in Reference Input Voltage versus Cathode Voltage

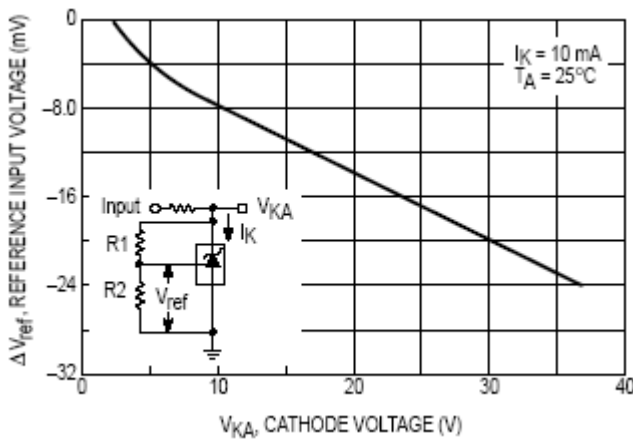

Figure 9. Off-State Cathode Current versus Ambient Temperature

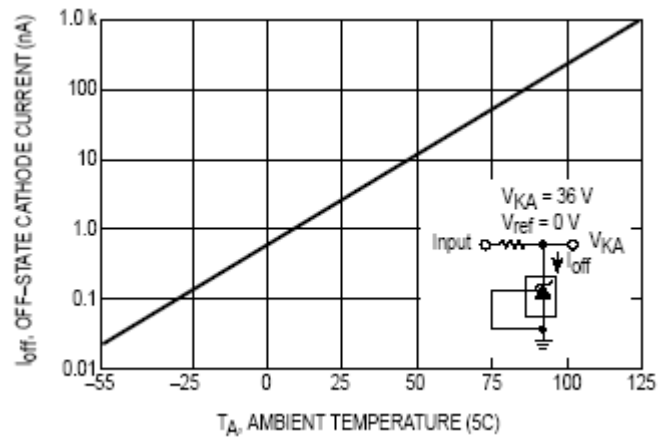

Figure 10. Dynamic Impedance versus Frequency

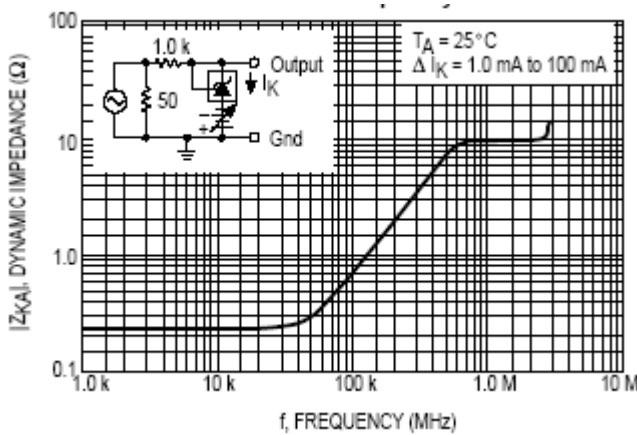

Figure 11. Dynamic Impedance versus Ambient Temperature

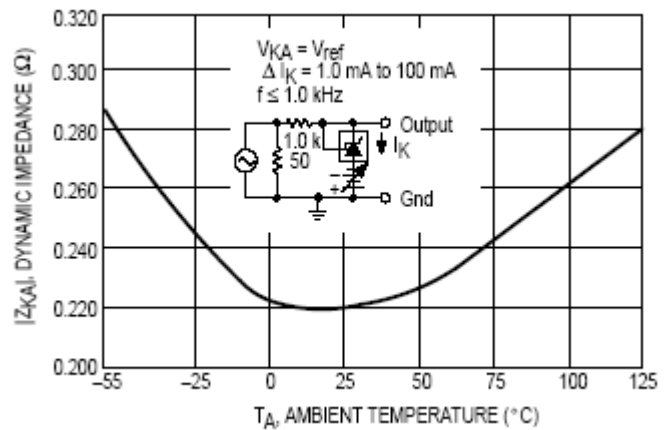

Figure 12. Open-Loop Voltage Gain versus Frequency

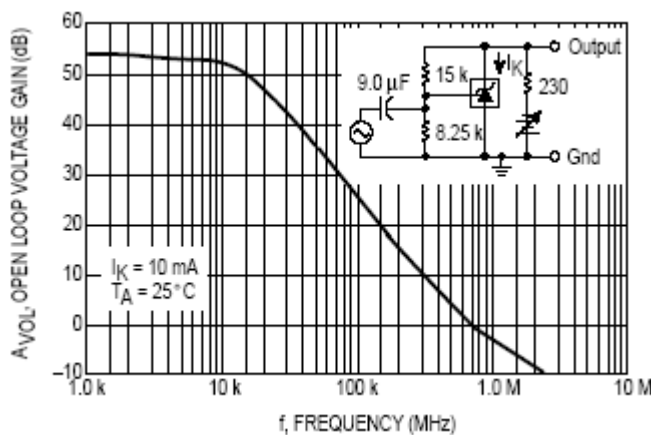

Figure 13. Spectral Noise Density

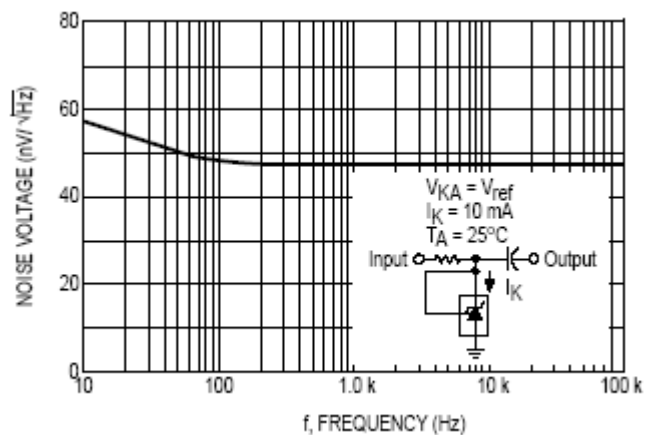

Figure 14. Pulse Response

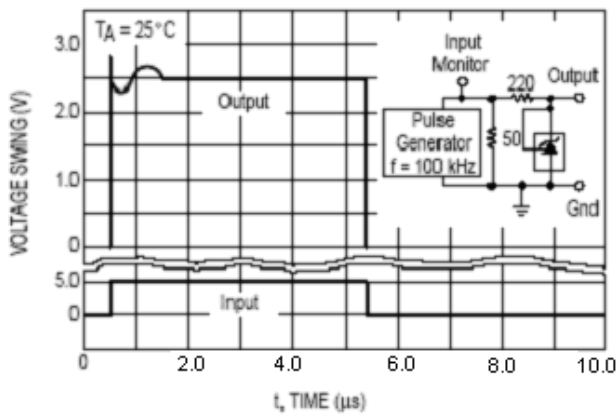

Figure 15. Stability Boundary Conditions

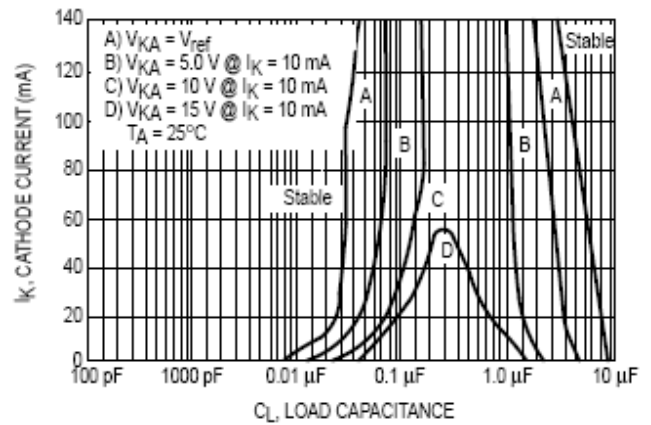

Figure 16. Test Circuit For Curve A of Stability Boundary Conditions

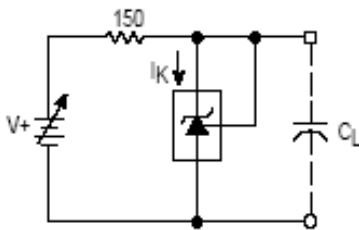
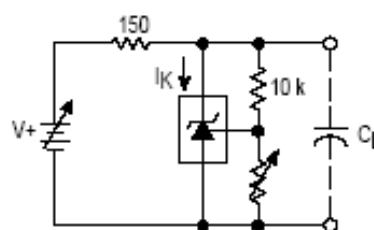

Figure 17. Test Circuit For Curves B, C, And D of Stability Boundary Conditions



TYPICAL APPLICATIONS

Figure 18. Shunt Regulator

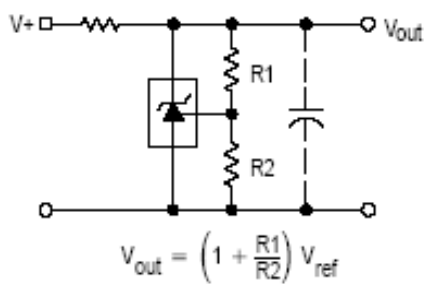

Figure 19. High Current Shunt Regulator

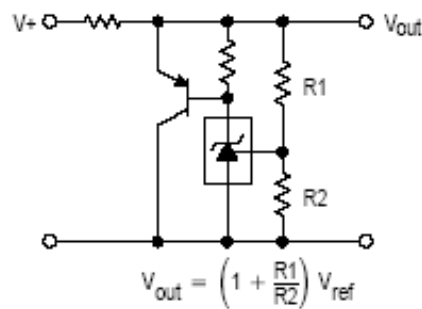

Figure 20. Output Control for a Three-Terminal Fixed Regulator

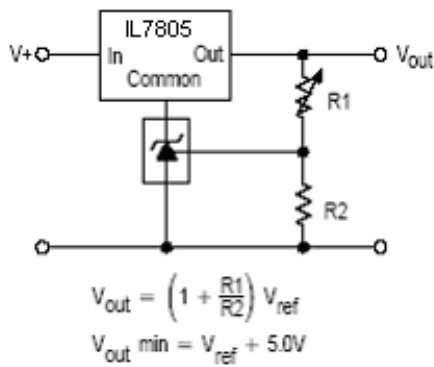

Figure 22. Constant Current Source

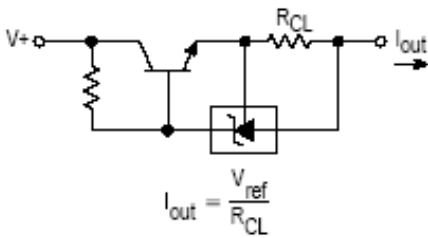

Figure 24. TRIAC Crowbar

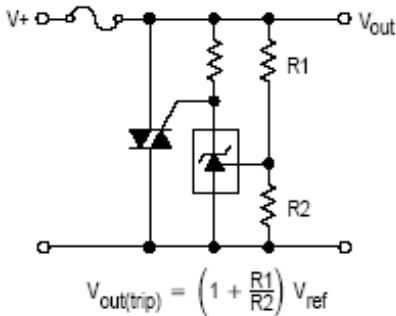

Figure 21. Series Pass Regulator

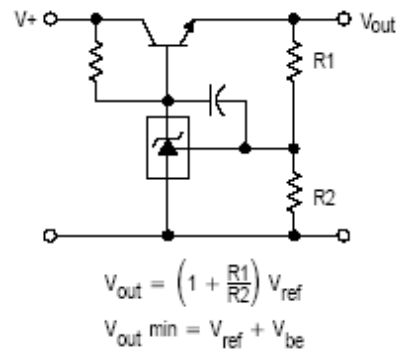

Figure 23. Constant Current Sink

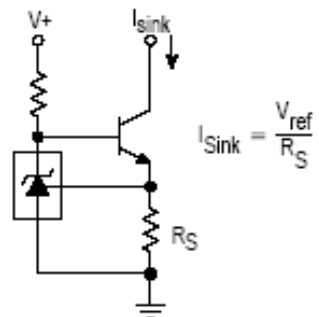

Figure 25. SRC Crowbar

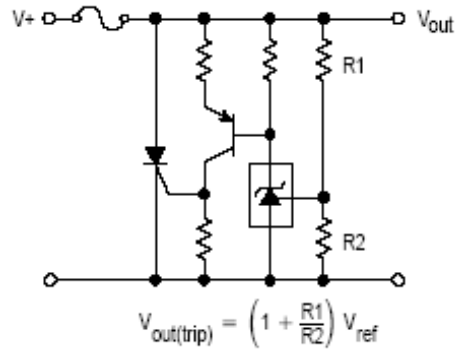
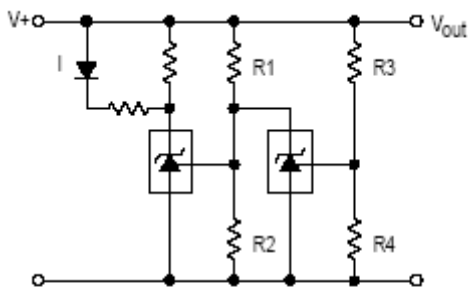

Figure 26. Voltage Monitor



L.E.D. indicator is 'on' when V+ is between the upper and lower limits.

$$\text{Lower Limit} = \left(1 + \frac{R1}{R2}\right) V_{ref}$$

$$\text{Upper Limit} = \left(1 + \frac{R3}{R4}\right) V_{ref}$$

Figure 28. Linear Ohmmeter

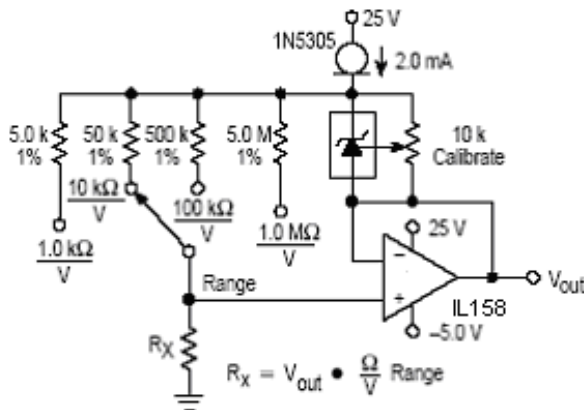

$$R_x = V_{out} \cdot \frac{\Omega}{V} \text{ Range}$$

Figure 27. Single-Supply Comparator with Temperature-Compensated Threshold

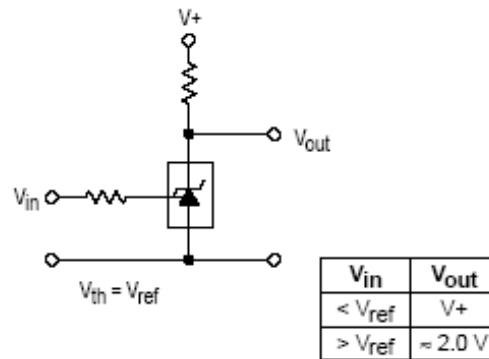

Figure 29. Simple 400 mW Phono Amplifier

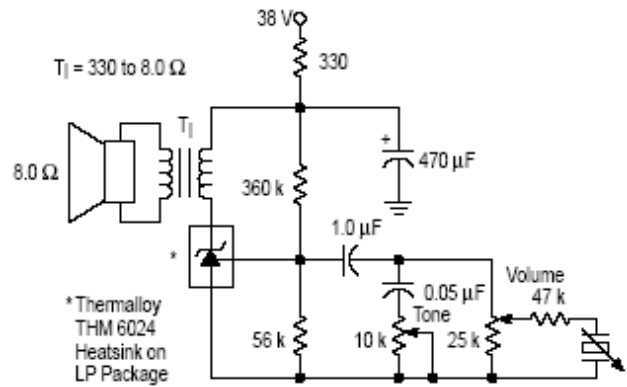
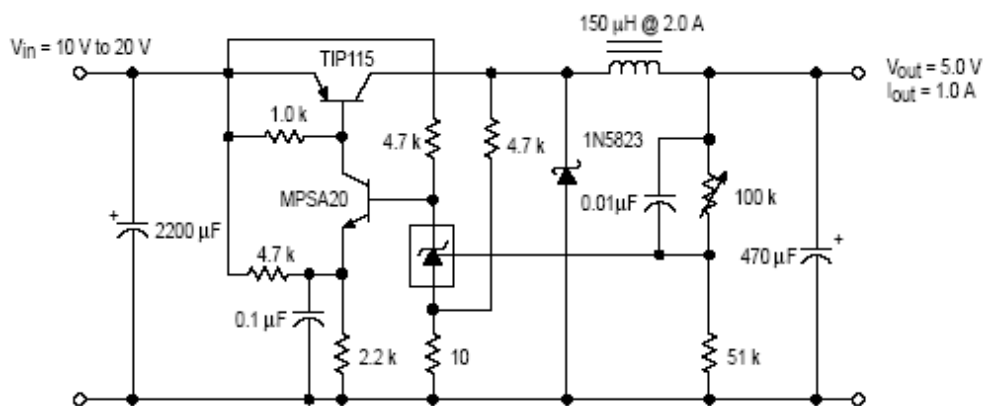

Figure 30. High Efficiency Step-Down Switching Converter



Test	Conditions	Results
Line Regulation	V _{in} = 10 V to 20 V, I _o = 1.0 A	53 mV (1.1%)
Load Regulation	V _{in} = 15 V, I _o = 0 A to 1.0 A	25 mV (0.5%)
Output Ripple	V _{in} = 10 V, I _o = 1.0 A	50 mVpp P.A.R.D.
Output Ripple	V _{in} = 20 V, I _o = 1.0 A	100 mVpp P.A.R.D.
Efficiency	V _{in} = 15 V, I _o = 1.0 A	82%

APPLICATIONS INFORMATION

The TL431Z is a programmable precision reference which is used in a variety of ways. It serves as a reference voltage in circuits where a non-standard reference voltage is needed. Other uses include feedback control for driving an optocoupler in power supplies, voltage monitor, constant current source, constant current sink and series pass regulator. In each of these applications, it is critical to maintain stability of the device at various operating currents and load capacitances. In some cases the circuit designer can estimate the stabilization capacitance from the stability boundary conditions curve provided in Figure 15. However, these typical curves only provide stability information at specific cathode voltages and at a specific load condition.

Additional information is needed to determine the capacitance needed to optimize phase margin or allow for process variation. A simplified model of the TL431Z is shown in Figure 31. When tested for stability boundaries, the load resistance is 150 Ω. The model reference input consists of an input transistor and a dc emitter resistance connected to the device anode. A dependent current source, G_m, develops a current whose amplitude is determined by the difference between the 1.78 V internal reference voltage source and the input transistor emitter voltage. A portion of G_m flows through compensation capacitance, C_{P2}. The voltage across C_{P2} drives the output dependent current source, G_o, which is connected across the device cathode and anode.

Model component values are:

$$V_{ref} = 1.78 \text{ V}$$

$$G_m = 0.3 + 2.7 \exp(-I_C/26 \text{ mA})$$

where I_C is the device cathode current and G_m is in mhos

$$G_o = 1.25 (V_{cp2})^2 \mu\text{mhos.}$$

Resistor and capacitor typical values are shown on the model. Process tolerances are ±20% for resistors, ±10% for capacitors, and ±40% for transconductances.

An examination of the device model reveals the location of circuit poles and zeroes:

$$P1 = \frac{1}{2\pi R_{GM} C_{P1}} = \frac{1}{2\pi * 1.0 \text{ M} * 20 \text{ pF}} = 7.96 \text{ kHz}$$

$$P2 = \frac{1}{2\pi R_{P2} C_{P2}} = \frac{1}{2\pi * 10 \text{ M} * 0.265 \text{ pF}} = 60 \text{ kHz}$$

$$Z1 = \frac{1}{2\pi R_{Z1} C_{P1}} = \frac{1}{2\pi * 15.9 \text{ k} * 20 \text{ pF}} = 500 \text{ kHz}$$

In addition, there is an external circuit pole defined by the load:

$$P_L = \frac{1}{2\pi R_L C_L}$$

Also, the transfer dc voltage gain of the TL431Z is:

$$G = G_M R_{GM} G_o R_L$$

Example 1:

$$I_C = 10 \text{ mA}, R_L = 230 \text{ } \Omega, C_L = 0. \text{ Define the transfer gain.}$$

The DC gain is:

$$G = G_M R_{GM} G_o R_L = (2.138)(1.0 \text{ M})(1.25 \mu)(230) = 615 = 56 \text{ dB}$$

$$\text{Loop gain} = G \frac{8.25 \text{ k}}{8.25 \text{ k} + 15 \text{ k}} = 218 = 47 \text{ dB}$$

The resulting transfer function Bode plot is shown in Figure 32. The asymptotic plot may be expressed as the following equation:

$$A_v = 615 \frac{\left(\frac{1 + jf}{500 \text{ kHz}} \right)}{\left(\frac{1 + jf}{8.0 \text{ kHz}} \right) \left(\frac{1 + jf}{60 \text{ kHz}} \right)}$$

The Bode plot shows a unity gain crossover frequency of approximately 600 kHz. The phase margin, calculated from the equation, would be 55.9 degrees. This model matches the Open-Loop Bode Plot of Figure 12. The total loop would have a unity gain frequency of about 300 kHz with a phase margin of about 44 degrees.

Figure 31. Simplified TL431Z Device Model

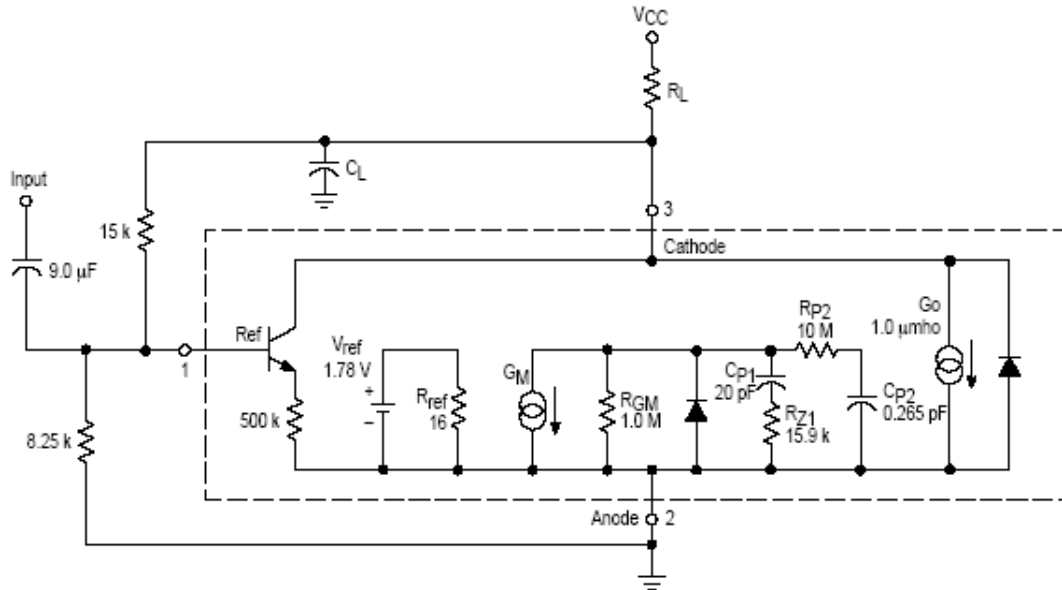

Figure 32. Example 1
Circuit Open Loop Gain Plot

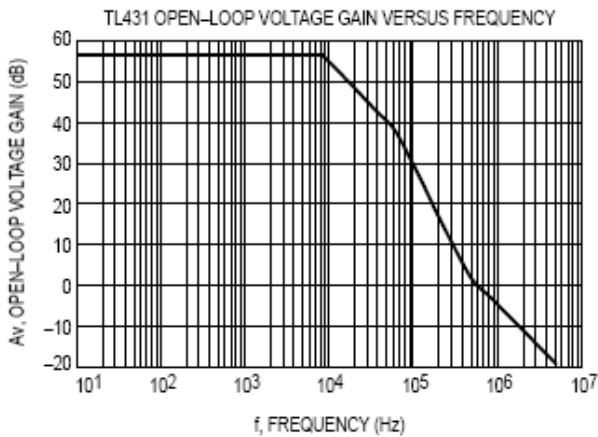
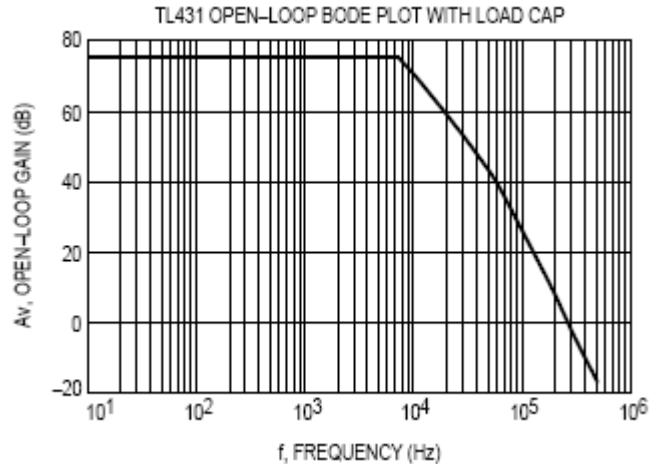

Figure 33. Example 2
Circuit Open Loop Gain Plot



Example 2.

$I_C = 7.5 \text{ mA}$, $R_L = 2.2 \text{ k}\Omega$, $C_L = 0.01 \mu\text{F}$.

Cathode tied to reference input pin. An examination of the data sheet stability boundary curve (Figure 15) shows that this value of load capacitance and cathode current is on the boundary. Define the transfer gain.

The DC gain is:

$$G = G_M R_{GM} G_o R_L = (2.323)(1.0 \text{ M})(1.25 \mu)(2200) = 6389 = 76 \text{ dB}$$

The resulting open loop Bode plot is shown in Figure 33. The asymptotic plot may be expressed as the following equation:

$$A_v = 615 \frac{\left(\frac{1 + jf}{500 \text{ kHz}} \right)}{\left(\frac{1 + jf}{8.0 \text{ kHz}} \right) \left(\frac{1 + jf}{60 \text{ kHz}} \right) \left(\frac{1 + jf}{7.2 \text{ kHz}} \right)}$$

Note that the transfer function now has an extra pole formed by the load capacitance and load resistance.

Note that the crossover frequency in this case is about 250 kHz, having a phase margin of about -46 degrees.

Therefore, instability of this circuit is likely.

With three poles, this system is unstable. The only hope for stabilizing this circuit is to add a zero. However, that can only be done by adding a series resistance to the output capacitance, which will reduce its effectiveness as a noise filter. Therefore, practically, in reference voltage applications, the best solution appears to be to use a smaller value of capacitance in low noise applications or a very large value to provide noise filtering and a dominant pole rolloff of the system.

Package Dimensions

TO-92

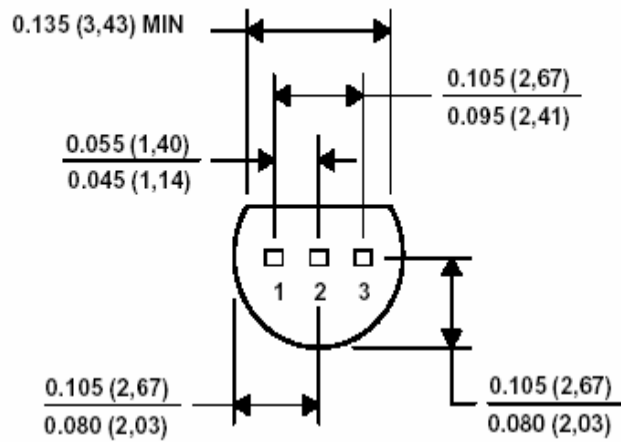
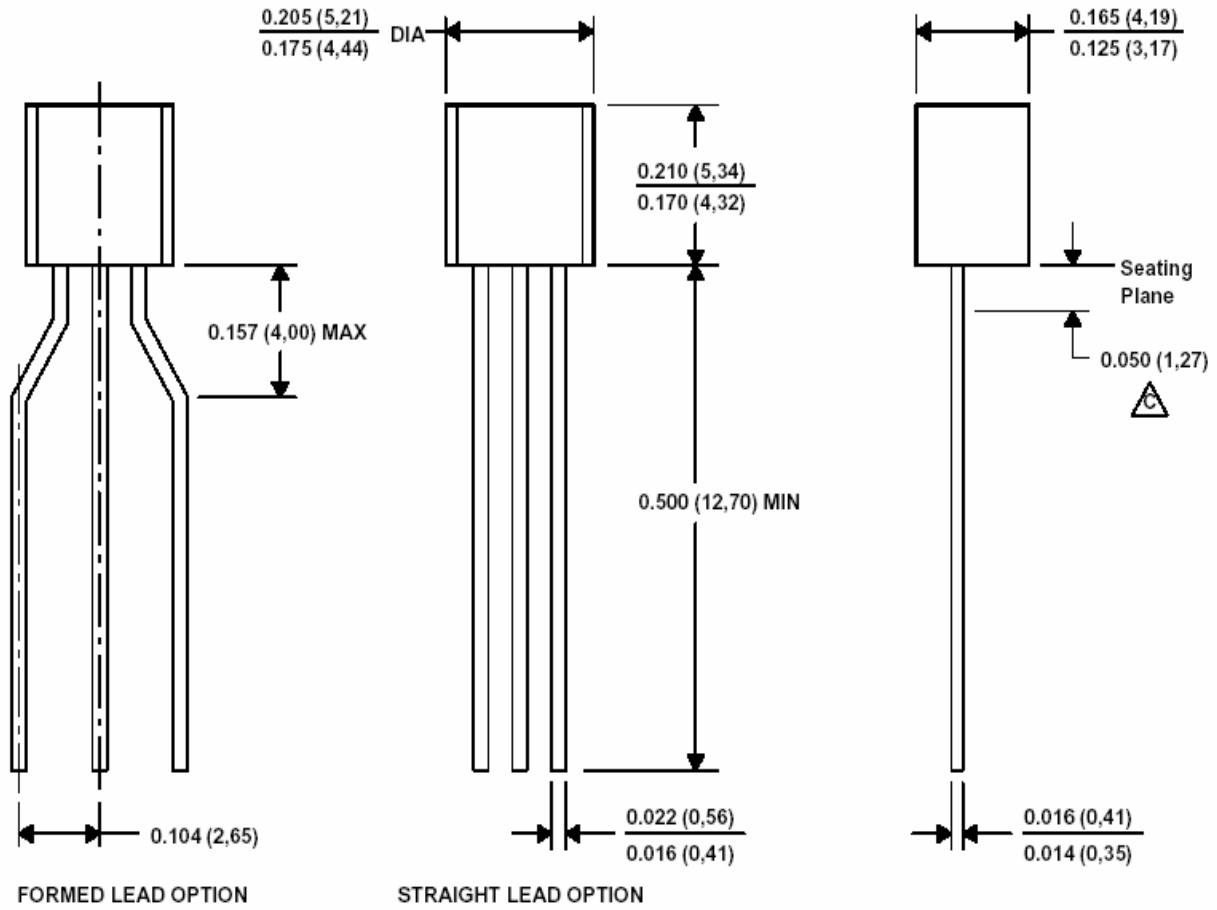

SOT-23-3L PACKAGE OUTLINE DIMENSIONS

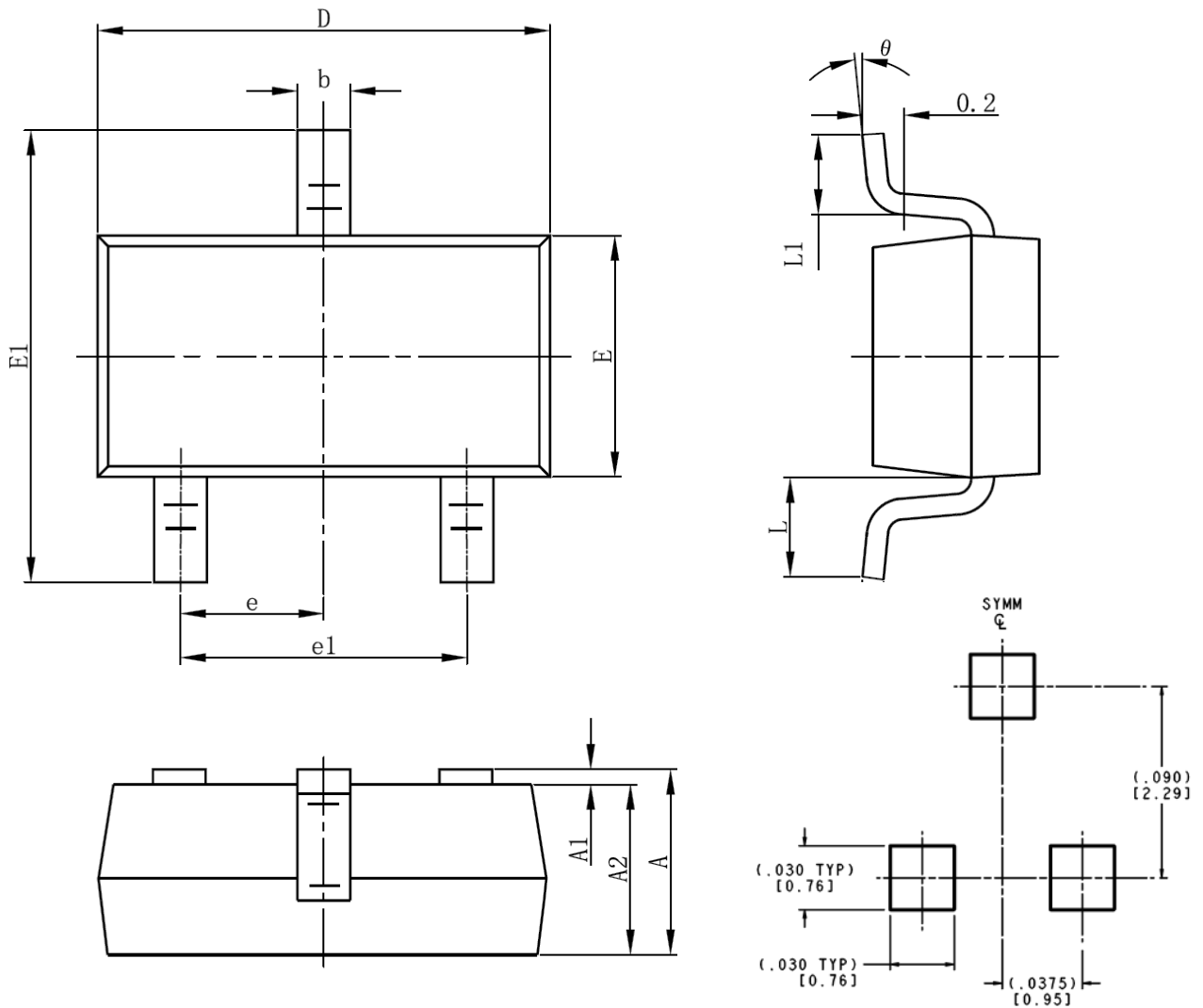

LAND PATTERN RECOMMENDATION

Symbol	Dimensions In Millimeters		Dimensions In Inches	
	Min	Max	Min	Max
A	1.050	1.250	0.041	0.049
A1	0.000	0.100	0.000	0.004
A2	1.050	1.150	0.041	0.045
b	0.300	0.400	0.012	0.016
c	0.100	0.200	0.004	0.008
D	2.820	3.020	0.111	0.119
E	1.500	1.700	0.059	0.067
E1	2.650	2.950	0.104	0.116
e	0.950TYP		0.037TYP	
e1	1.800	2.000	0.071	0.079
L	0.700REF		0.028REF	
L1	0.300	0.600	0.012	0.024
theta	0°	8°	0°	8°

SOT-89-3L PACKAGE OUTLINE DIMENSIONS

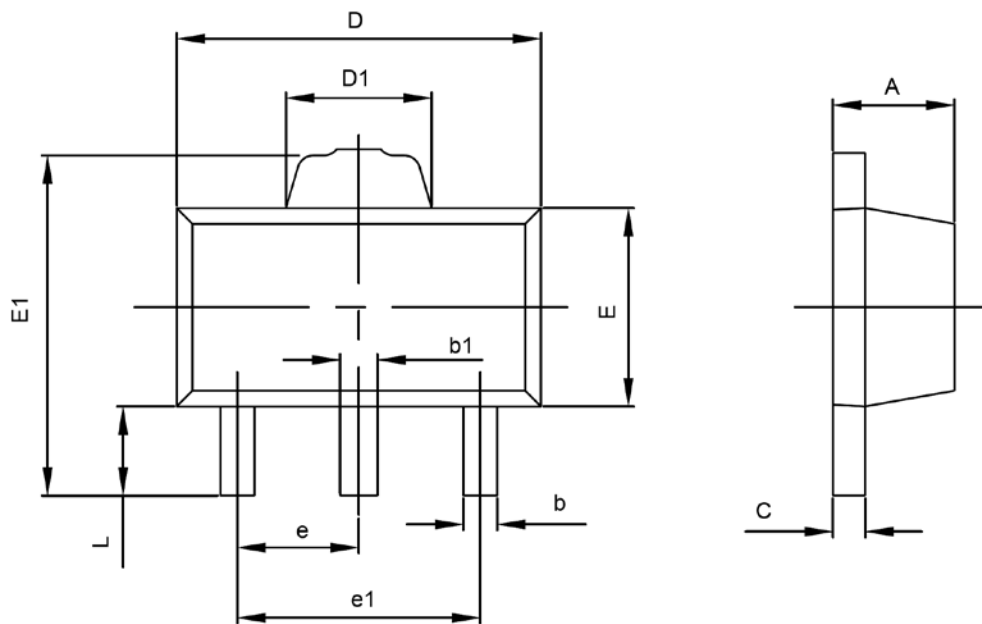

Symbol	Dimensions In Millimeters		Dimensions In Inches	
	Min	Max	Min	Max
A	1.400	1.600	0.055	0.063
b	0.320	0.520	0.013	0.020
b1	0.360	0.560	0.014	0.022
c	0.350	0.440	0.014	0.017
D	4.400	4.600	0.173	0.181
D1	1.400	1.800	0.055	0.071
E	2.300	2.600	0.091	0.102
E1	3.940	4.250	0.155	0.167
e	1.500TYP		0.060TYP	
e1	2.900	3.100	0.114	0.122
L	0.900	1.100	0.035	0.043